

SMOKE & CO COMBO ALARM

CAT. **SC7010BVA**



OptiPath 360™
Technology

**10-YEAR CO SENSOR
10-YEAR ALARM LIFE**

SMOKE & CO COMBO

Electrochemical CO sensor;
Photoelectric smoke sensor.

VOICE WARNING WITH LOCATION

Exclusive! A voice will tell you the
programmed location of the unit
and danger detected.

SILENCE FEATURE

Silences nuisance alarms.

END OF LIFE SIGNAL

Provides audible notice when alarm
needs to be replaced after 10 years.

SPREAD SPECTRUM HORN TONE

Easier for elderly with normal age
related hearing loss to hear the horn.

OPTIPATH 360 TECHNOLOGY™

Provides 360 degrees of direct
access to the smoke sensing
chamber.



BRK®

THE PROFESSIONAL STANDARD

**120V AC, 60Hz Wire-in
with 3V (two 1.5V AA) Battery Backup**

Description:

BRK Model SC7010BVA is a wire-in, 120V AC 60Hz single and/or multiple station combination smoke and carbon monoxide alarm specifically designed for residential and institutional applications including sleeping rooms of hospitals, hotels, motels, dormitories and other multi-family dwellings as defined in standard NFPA 101. Model SC7010BVA complies with ULC S531, CSA 6.19-01, NFPA 72 and NFPA 720, HUD, FHA and other agencies that model their codes after the above agencies. It meets building codes where AC/DC photoelectric smoke and carbon monoxide alarms with and without voice are required.

BRK SC7010BVA is a state-of-the-art hardwired with battery backup smoke/CO combo alarm that features a photoelectric smoke sensing chamber, an electrochemical CO sensor, an End of Life signal and voice warning with location. This exclusive feature incorporates a voice that will speak one of 11 pre-programmed locations and the danger detected. The Spread Spectrum Horn Tone has a lower and varying frequency that makes it easier for the elderly with normal age related hearing loss to hear the horn. This alarm features two latching features and two silence features. Alarm Latch: Easily identifies initiating alarm even after alarm condition has subsided. Low Battery Latch: Identifies which unit is in low battery condition by blinking the green power light. Low Battery Silence: Temporarily silence the low battery chirp for up to eight hours. Alarm Silence: Silence alarm for several minutes. Other features include an 85dB horn and silence. OptiPath 360 Technology provides 360 degrees of direct access to the smoke sensor. Two locking features are provided to prevent battery theft and/or theft of the unit. Connection to AC power is made with a Quick-Connect wiring harness.



CAT. SC7010BVA

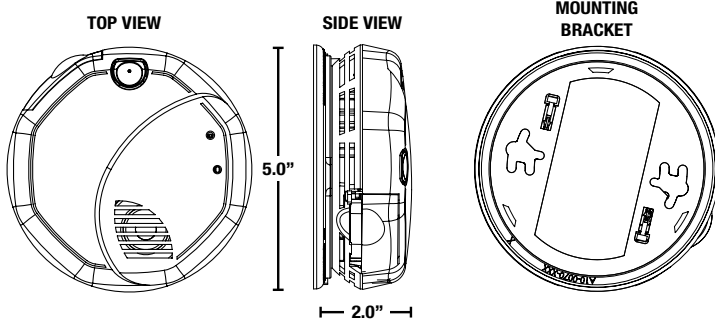

ARCHITECTURAL AND ENGINEERING SPECS

The combination smoke and carbon monoxide alarm shall be a BRK Model SC7010BVA and shall provide at a minimum the following features and functions:

1. A photoelectric smoke sensing chamber and an electrochemical CO sensor both with a 10 year service life.
2. Powered by 120V AC, 60Hz and have a monitored battery backup and a solid state piezo horn rated at 85dB at 10 ft. and shall be capable of self restoring. The horn shall have a lower and varying horn frequency to make it easier for the elderly with normal age related hearing loss to better hear the horn.
3. A Voice Warning of Smoke or Carbon Monoxide detected in addition to speaking 11 pre-programmed locations, e.g. "Warning, Evacuate, Smoke in Basement"
4. The unit shall have an "End of Life" signal. This signal should be capable of temporarily being silenced for up to 2 days. After about 2 days, the signal will resume. After about 2-3 weeks the signal cannot be silenced.
5. A visual power-on indicator to confirm unit is receiving AC power or has switched to battery backup mode. Separate LED's to indicate a smoke or CO alarm.
6. The CO sensor is adjusted not to detect CO levels below 30 PPM and will not alarm when exposed to constant levels of 30 PPM for 30 days. It will alarm at the following levels: 400 PPM CO between 4 and 15 minutes, 150 PPM CO between 10 and 50 minutes and 70 PPM CO between 60 and 240 minutes.
7. Two Latching features: Alarm Latch to easily identify initiating alarm after alarm condition has subsided. Low battery latch: to visually identify which unit is in low battery condition. Two Silence Features: Alarm Silence to temporarily silence nuisance alarms. Low Battery Silence to silence low battery chirp for up to 8 hours.
8. Two Locking features - tamper resistant locking pins that lock battery drawer and/or alarm to mounting bracket.
9. The unit shall be capable of operating between 40°F (4°C) and 100°F (38°C) and relative humidity between 10% and 95%.
10. The unit shall have a plug in connector and be capable of interconnection of up to 18 alarms, 12 of which can be smoke alarms.
11. The unit shall at a minimum meet the requirements of ULC S531, CSA 6.19-01, NFPA 72 and 720 and the ICC.

INSTALLATION OF ALARM

Installation of this smoke alarm must conform to all local electrical codes and Article 760 of the National Electrical Code (NFPA 70) and NFPA 72. Interconnected units must meet the following requirements: Total length of wire interconnecting units should be less than 1000 feet, be #18 gauge or larger and be rated at least 300V. It is recommended that all units be on the same fuse or circuit breaker. If local codes do not permit, be sure the neutral wire is common to both phases.

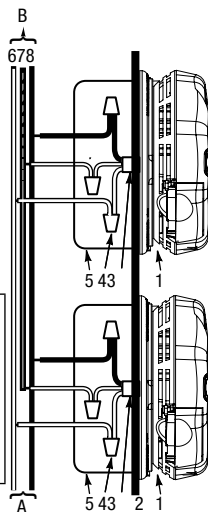

THE PARTS OF THIS ALARM

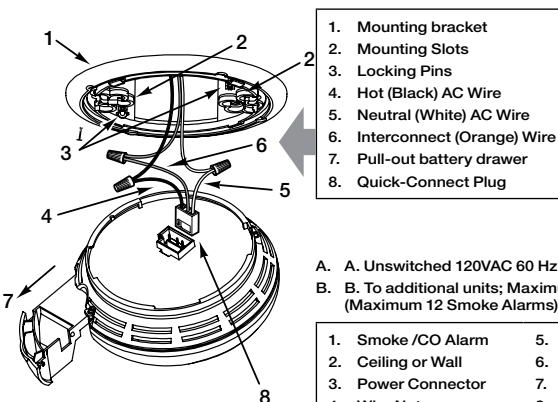

- | | |
|-------------------------------|-------------------------------|
| 1. Mounting bracket | 5. Junction Box |
| 2. Mounting Slots | 6. Neutral Wire (White) |
| 3. Locking Pins | 7. Interconnect Wire (Orange) |
| 4. Hot (Black) AC Wire | 8. Hot Wire (Black) |
| 5. Neutral (White) AC Wire | |
| 6. Interconnect (Orange) Wire | |
| 7. Pull-out battery drawer | |
| 8. Quick-Connect Plug | |
- A. A. Unswitched 120VAC 60 Hz source
 B. B. To additional units; Maximum = 18 total (Maximum 12 Smoke Alarms)

TECHNICAL SPECS

Alarm Dimensions:	5.0" Dia. x 2.0" H
Weight:	9.3 oz
Operating Voltage:	120V AC 60Hz with 3V alkaline battery backup (two 1.5V)
Operating Current:	0.05 amps (standby/alarm)
Temperature Range:	40°F (4°C) to 100°F (38°C)
Humidity Range:	10% to 95% relative humidity (RH)
Audio Alarm:	85dB at 10 feet
Test/Silence:	Electronically simulates smoke or CO condition, causing the unit to alarm. Press and hold test/silence button.
Alarm Reset:	Automatic when smoke or CO clears
Interconnections:	Up to 18 units of First Alert or BRK Smoke, CO and Heat Alarms. Maximum of 12 smoke alarms. See user's manual for details.
Smoke Sensor	Photoelectric
CO Sensor:	Electrochemical
Indicator Lights/Sounds:	
AC Power:	Constant Green LED
DC Power:	Intermittent Green LED
Local Alarm:	Red LED flashes rapidly
Remote Alarm:	Red LED off
Latching Alarm:	Red LED flashes every 5 seconds after local alarm
Low Battery Latch:	"Power" LED flashes green on for 2 sec, off for 2 sec
End of Life:	5 green LED flashes, 5 chirps once per minute
Listing:	Certified to ULC STD S531 & CSA 6.19-01

SHIPPING SPECS

Individual Carton Dimensions	2.4" L x 5.1" W x 5.1" H
Weight:	0.8 lbs.
Cube:	0.03 ft ³
UPC:	0 29054 01292 0
Master Carton Dimensions	10.7" L x 7.6" W x 10.8" H
Master Pack:	12
Weight:	9.5 lbs.
Cube:	0.3 ft ³
I2of5:	200 29054 01292 4
Pallet Information	
Cases per Layer:	22
Number of Layers:	4
Cases per Pallet:	88
Units per Pallet:	1,056
Cube:	52.7 ft ³
Weight:	866 lbs.

BATTERY DRAWER LOCK

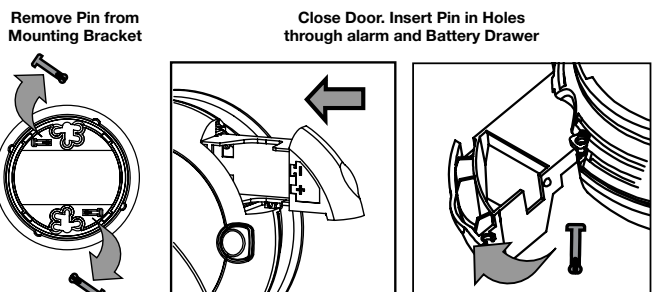

© 2021 BRK Brands, Inc. All rights reserved. Distributed by BRK Brands, Inc., Aurora, Illinois 60504. BRK Brands, Inc. is a subsidiary of Newell Brands Inc. (NASDAQ: NWL). Rev 10/20

brkcanada.ca